

2026

Porcelain gres  
cutting and  
processing



**DISTAR**

Work EASIER. Build FASTER.

distar.tools

**Clean cutting** Ø 100-125



**Perfect**

Edge quality ●●●●●+      Speed ●●●●●  
 Wet cutting quality in dry cutting mode.  
 Rigid and stable.



**Scalpel**

Edge quality ●●●●●      Speed ●●●●○  
 Fine ultra-thin cutting of ceramics without chipping.



**Elegant**

Edge quality ●●●●●++      Speed ●●●●○  
 Porcelain furniture production.  
 Mosaic and glass cutting.



**MasterCUT**

Edge quality ●●●●●+      Speed ●●●●●  
 Universal, high-speed, finish cutting  
 of glazed tiles, mosaics, glass.



**MasterGRIND**

Edge quality ●●●●●      Speed ●●●●●  
 Grinding and precision finishing cuts of  
 glazed tiles, mosaics, and glass.



**Esthete 2.0/Esthete**

Edge quality ●●●●●+      Speed ●●●○○  
 Cleanest cut, work well with corded and  
 cordless angle grinders.



**SHINE**

Edge quality ●●●●●++      Speed ●●●●●  
 The thinnest diamond layer is only  
 0.6 mm.



**Spray**

Water supply system.  
 Water flow rate: 45 ml/min.

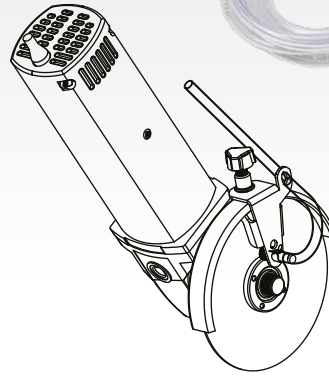

**Fast cutting** Ø 115-125



**Gres Master**

Edge quality ●●●●●      Edge quality ●●●●○  
 Fast cutting of 20 mm thick material with  
 hand-held tile cutters.



**Multigres**

●●●●○      ●●●●○  
 Fast precutting for trim and molding  
 installation.



**Decor Slim**

●●●●○      ●●●●○  
 Optimal speed and quality ratio.

**Roller**

Dust removal and  
 comfortable cutting.



**Special application**



**Cleaner** Ø 101,6

Edge quality ●●●●○      Speed ●●●●●  
 Tile grout cutting. Thickness 0,8 mm.



**LevelCUT** Ø 60

●●●●○      ●●●●●  
 For glue undercutting.

**Abrasive**

For diamond  
 blades sharpening.

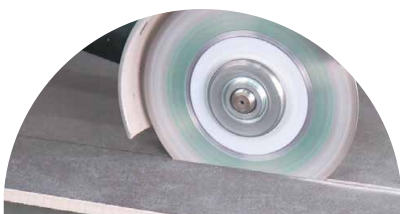

**For handheld engravers**

**Butterfly Ø 45, 50**

Edge quality ●●●● Speed ●●●●



For fine detailing in porcelain stoneware.

**Butterfly Ø 45**

Edge quality ●●●●+ Speed ●●●●



Ultra-thin cutting for seamless pattern alignment on tiles.

**MasterCUT Ø 45**

Edge quality ●●●● Speed ●●●●



Precise cutting of porcelain stoneware, even in dry conditions.

**Support**

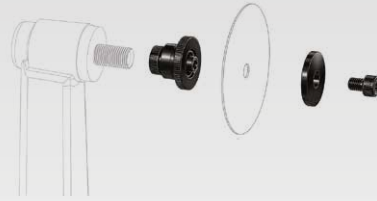

Cutting stabilization.



**Nectar Ø 45**

Edge quality ●●●● Speed ●●●●+



High-speed grinding in hard-to-reach areas.

**SoftEdge Ø 45**

Edge quality ●●●● Speed ●●●●



Semi-fine grinding prior to polishing.

**COOLPAD Ø 50**

Edge quality ●●●●+ Speed ●●●●



High-performance, clean grinding of porcelain stoneware. #1, #2, #3

**Polishing Support**



Stabilization of cutting and grinding.

**Jolly cutting Ø 115-125**



**Galaxy**

Edge quality ●●●●+ Speed ●●●●

For fast and clean beveling of hard porcelain stoneware.



**Edge Dry**

Edge quality ●●●● Speed ●●●●

Hard porcelain gres cutting, clean straight and miter cutting.



**ProGres**

Edge quality ●●●● Speed ●●●●

Porcelain gres cutting, straight and miter cutting.

**Glider 45**

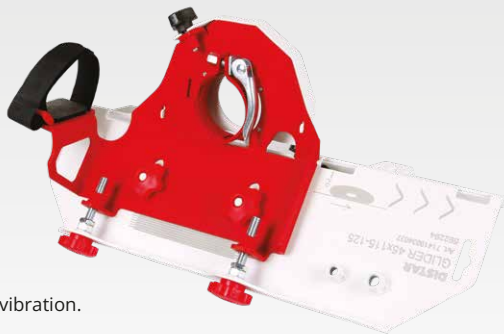

45° cutting without vibration.

**Slider 45 PRO**



Professional miter cutting of medium and large tile formats.

**Slider 45**



Comfortable cutting at 45 degrees.

**Duster 115-125**



Dust-free cutting at any angle. Reduces hand strain.

**Mini tools 76**

**SHINE** Ø 76

Edge quality ●●●●●+ Speed ●●●●●+



Ultra-thin diamond layer of just 0.6 mm.

**Colibri** Ø 76

Edge quality ●●●●● Speed ●●●●●○



Fine cutting of porcelain stoneware with a mini angle grinder.

**Termit** Ø 76

Edge quality ●●●●○ Speed ●●●●●



Fast miter cutting.

**Roller 76**



Dust removal and convenient cutting with a mini angle grinder.

**Grinding**

**StandART**

Edge quality ●●●○

Speed ●●●○

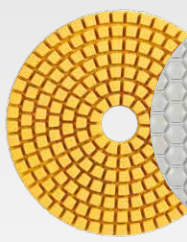

Grinding of lightweight porcelain stoneware #30 - 3000

**CleanPAD**

Edge quality ●●●●○

Speed ●●●○



Excellent grinding quality. #0, #50, #100, #200, #400, #800

**CoolPAD**

Edge quality ●●●●●

Speed ●●●●●



Highly productive clean grinding of porcelain stoneware. #0, #1, #2, #3

**Click-Lock PRO**



Quick change of polishing pads. Magnetic fixation. Save your Velcro.

**Liner 115-125**



Adjustable grinding guide with dust extraction system.

**Click-Lock UNI**



Instantly go from cutting to grinding.

**Centrum PRO**



Aluminum polishing pad base with centering.

**Centrum FLEX**



Flexible polishing pad base with centering.

**EdgeDUSTER**



Dust-free polishing.

**HandPAD**



Manual grinding of porcelain stoneware. Available in three grit sizes. #1, #2, #3

**Hard Ceramics**

Edge quality ●●●○

Speed ●●●●●



Highly productive grinding. Two grit sizes: 60, 100.

**SoftEdge** Ø 115

Edge quality ●●●●●

Speed ●●●●●



Semi-fine grinding before polishing.

**TileDuster 115-125**



Dust extraction system for PORCELAIN grinding.

**Grinding**

**Grinding nut**

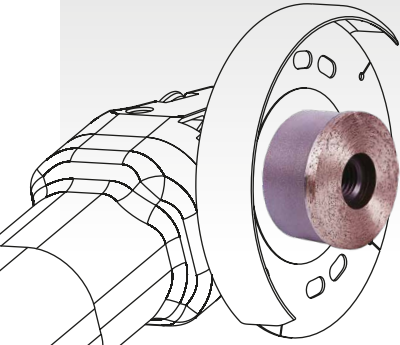

Grinding without removing the blade.

**Green Point**



Removal of paint and polymer coatings.

**Pro-tech**



Concrete grinding.

**Vortex**



Dust extraction for grinding.

**For tile cutters**



**Hard Ceramics Advanced**  
Ø 180-400

Edge quality ..... Speed .....

Fast finishing cut of thick porcelain stoneware.



**Hard Ceramics Advanced** Ø 115

.....

Used on machines such as Wandeli, Shijing and others. Fast and clean.



**Hard Ceramics** Ø 180-400

.....

Balance between speed, quality and lifetime.



**Edge** Ø 180-250

.....+ .....

For 45 degree cutting. Super clean.



**Granite Premium** Ø 180-400

.....

For high quality granite cutting.



**Scorpion**

Two-way water supply on all tile cutters.

**Drilling**

**Rocket** Ø 20-68



Segmented drill bit for dry drilling with an angle grinder: up to 300 holes without cooling.

**Keramik Pro 6-70**



High-speed drilling. Suitable for angle grinders, drills, and screwdrivers. Available with shanks S10 and M14.

**CoolGel**

Drill cooling + cleanliness.



**EasyFix 70**



Compact drilling template.

**DrillDuster 82**



Clean, dry drilling.

**TileTemplate**

Quick tile marking.



## Transportation systems

### UnoFix

Single suction cup for tile handling.



### DuoFIX

Double suction cup for tile handling.



### MiniFix

For laying small tiles and precise drilling.  
Included: 50 mm and 80 mm suction cups,  
a metal drilling template for holes with  
diameters from 6 to 70 mm.



## Tiling workbenches

### CeraMAX 1200 TELESCOPE



Multifunctional ergonomics.  
Shelves, brackets, magnets  
for tools. Adjustable height,  
wide profile, rubber shock  
absorbers.

### CeraMAX 1200/2.0



Multifunctional ergonomics.  
Shelves, brackets, tool magnets.

### CeraMAX 1800

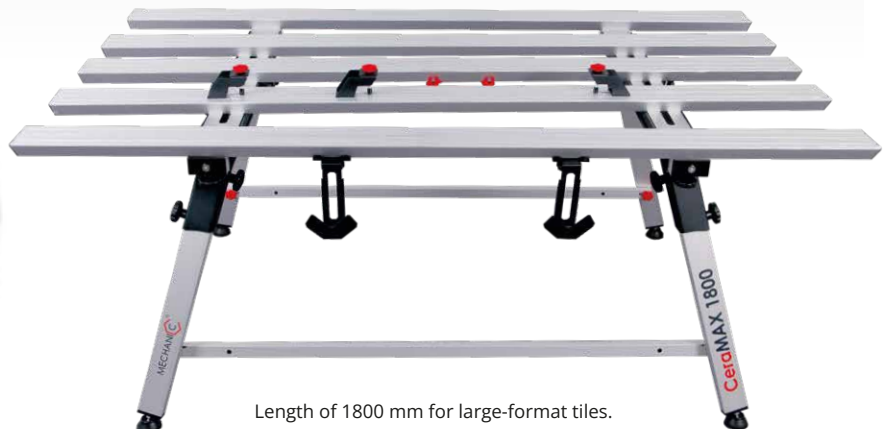

Length of 1800 mm for large-format tiles.





# DISTAR

Diamond tools  
for builders,  
electricians,  
plumbers



[distar.tools](https://distar.tools)

## Dry drill bits for microshock drilling $\varnothing$ 32-300 mm (dry mode)



**RM-TX**



Speed: ●●●●●+  
Lifetime: ●●●●●

Universal application.

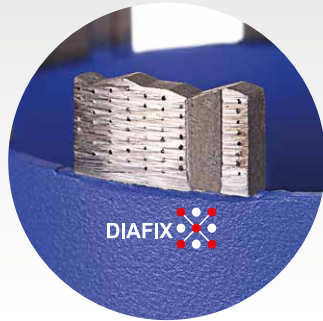

**RS-TX**



Speed: ●●●●●+  
Lifetime: ●●●●●

Hard, unreinforced and lightly reinforced concretes.



**Centrator\***  
Easy and fast start of drilling.  
 $\varnothing$  32-200 mm

**Centrator Spring\***  
Easy, fast centering, and start of drilling. Spring-loaded centralizer.  
 $\varnothing$  42-122 mm  
 $\varnothing$  132-162 mm

\* for drill bits RM-TX, RS-TX, Concrete-X

**DrillSTREAM**  
Dust extraction through the drill shaft.

1 1/4 UNC M18  
1 1/4 UNC  
1 1/4 UNC  
1 1/4 UNC

0,5 kg

Lightweight aluminum dust extraction.

**Concrete-X**

Speed: ●●●●●+  
Lifetime: ●●●●●

For a variety of light materials: concrete, brick, foam concrete.

M16

**Aluminum extensions**

**Extender**  
1 1/4 UNC

Aluminum lightweight extensions.

200 mm  
300 mm  
500 mm

## Dry socket drills $\varnothing$ 68, 72, 82 mm (dry mode)

**Krone PRO**

Speed: ●●●●●  
Lifetime: ●●●●●

For brick, price oriented.

**T-Concrete**

Speed: ●●●●●  
Lifetime: ●●●●●

For concrete and brick. Quick change of magnetic adapter.

SDS plus **MAGNET**

**CS-X**

Speed: ●●●●●  
Lifetime: ●●●●●

For concrete and brick, also with microshock.

**XXX MICROSHOCK**  
DIAFIX

**RS-X**

Speed: ●●●●●+  
Lifetime: ●●●●●

For highly reinforced concrete.

**XXX MICROSHOCK**  
DIAFIX

## Blades for chasing $\varnothing$ 125-230 mm

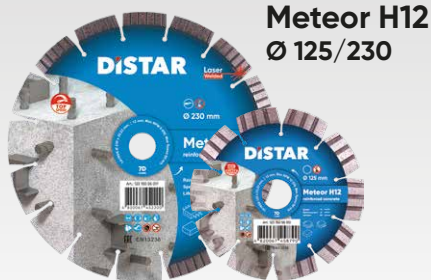

**Meteor H12**  
 $\varnothing$  125/230



Speed **••••**  
Lifetime **•••••**

Heavy reinforced concrete, bricks, etc. materials hard in processing.



**Technic Advanced**  
 $\varnothing$  125/150/  
180/230



Speed **•••••**  
Lifetime **•••**

For reinforced concrete, brick, etc. light materials.



**Rapid**  
 $\varnothing$  125/230



Speed **••••**  
Lifetime **•••**

For concrete, brick, etc. light materials.

## Dust extractors for chasing $\varnothing$ 115-125/230 mm

### AirDUSTER 115-125/230

Universal dust extraction.  
For all angle grinders.



### AirCHASER 115-125/230

The accessory for wall chasing.  
Adjustable cutting depth.



### FireFLY

A flashlight to illuminate the work area.  
For all angle grinders.

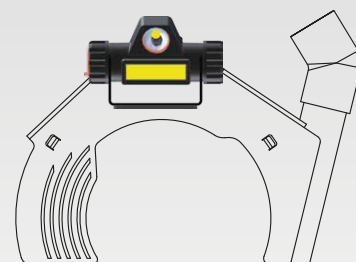

## Dust extractors for drilling $\varnothing$ up to 162 mm



### SocketDUSTER for drill bits CS-X

Dust extraction for socket drill bits.



### DrillDUSTER $\varnothing$ up to 82 mm

Dust extraction from the drilling area.



### AquaDUSTER $\varnothing$ up to 162 mm

Extracting water and dust from the drilling area.





## Wet drilling

### RS8-X DIAFIX

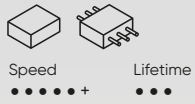

Heavy reinforcement.

### RS7-X DIAFIX

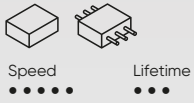

Heavy reinforcement.



### RS7

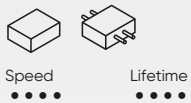

Reinforcement.

### RS6

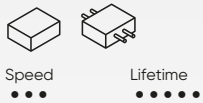

Reinforcement.

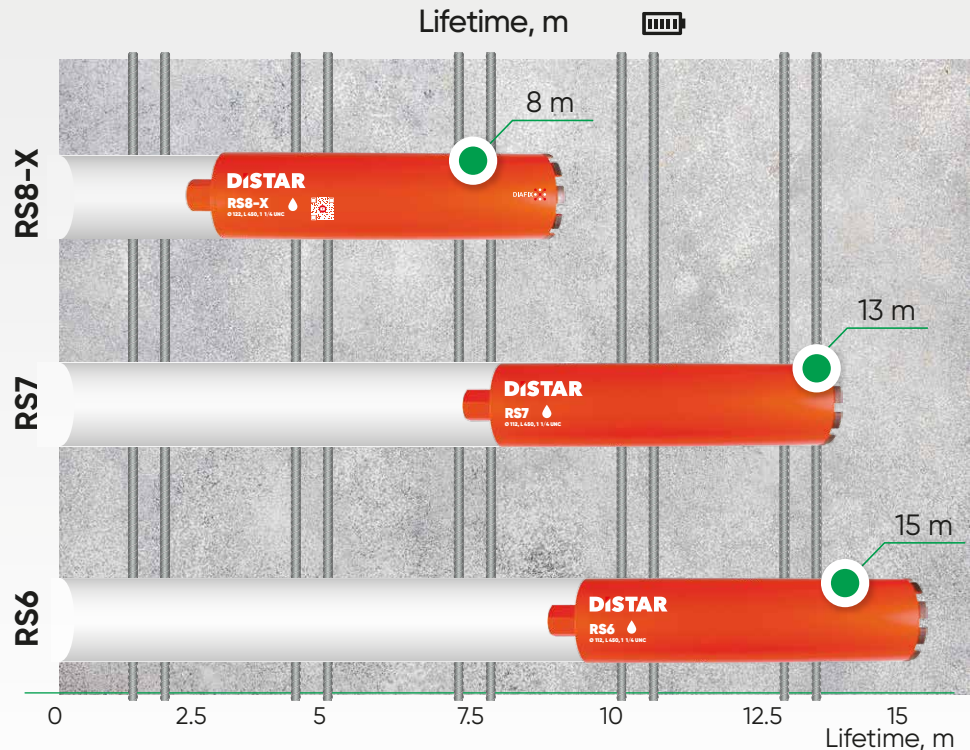
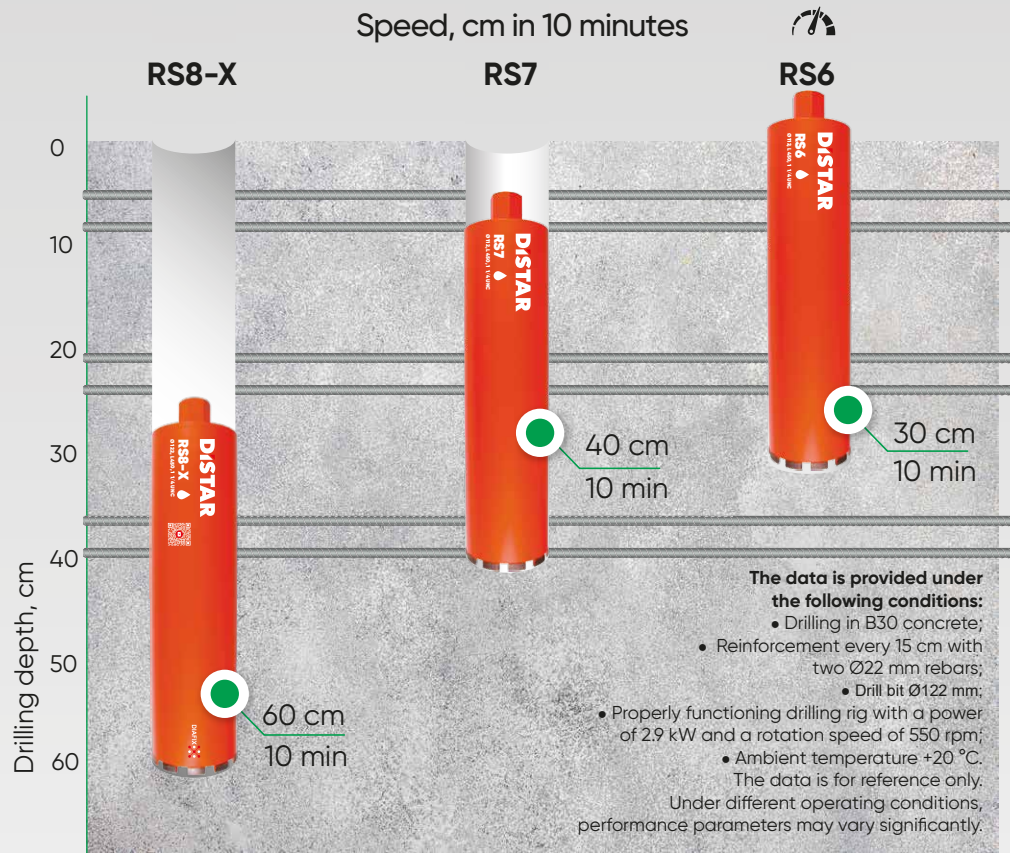

## Steel extensions

### Extension 1/2 GAS

200 mm  
300 mm  
500 mm



### Extension 1 1/4 UNC

200 mm  
300 mm  
500 mm

